



3651 N Highway 89 • Chino Valley, AZ 86323
(928) 636-3100 • www.orfab.com

**JEEP WRANGLER RUBICON
(TJ / YJ)
UNLIMITED (TJL)
ROCK SLIDER REAR BUMPER
INSTALLATION INSTRUCTIONS
1987-2006 KIT # 83100**

⚠ WARNING
Read and understand all instructions, warnings, cautions, and notes in this sheet and in your owner's manual before you install this kit.

⚠ WARNING
The Jeep Wrangler is rated as a Class I tow vehicle. See owner's manual. The kit **bumper** is equipped with a 2" receiver for vehicle recovery purposes. The kit **bumper** is NOT rated for towing.

Before starting installation

⚠ NOTE
Kit parts are prefaced by the word **kit** and appear in **bold print**.

- Carefully read all warnings and instructions completely before beginning.
- Verify all parts have been received in this kit by checking the parts list at the end of this document.
- Only install this kit on the vehicle for which it is specified.** If anytime during the installation you encounter something different from what is outlined in the instructions, call technical support at: (928) 636-3100.
- Park the vehicle on a clean, dry, flat, level surface and block the tires so the vehicle cannot roll in either direction.

Install kit

- Stock bumper
 - Remove bolts securing stock bumper to bottom of frame. If equipped with tow hooks, remove additional bolts and tow hooks.

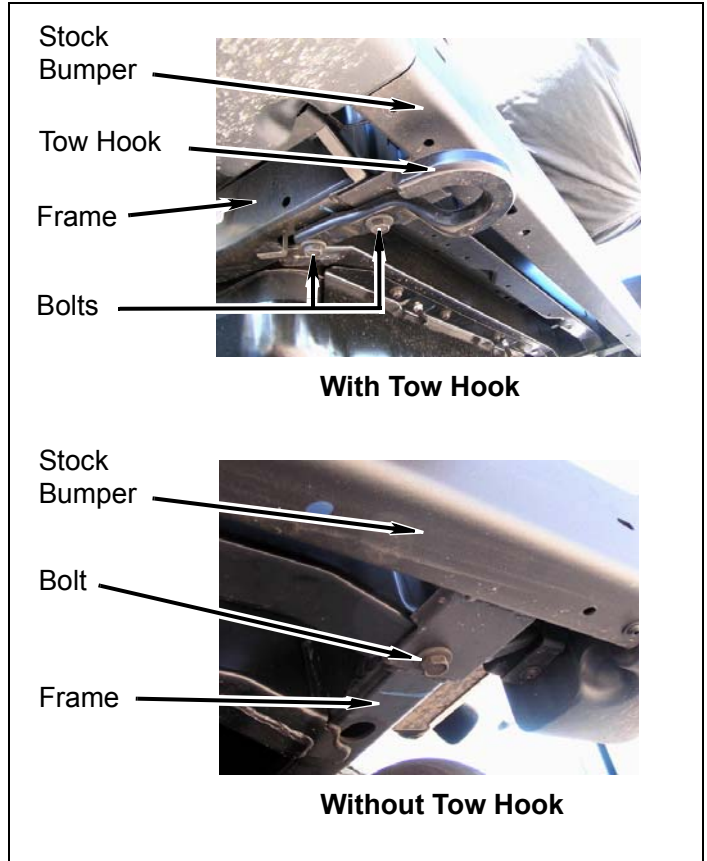

- Remove four nuts and stock bumper from frame.

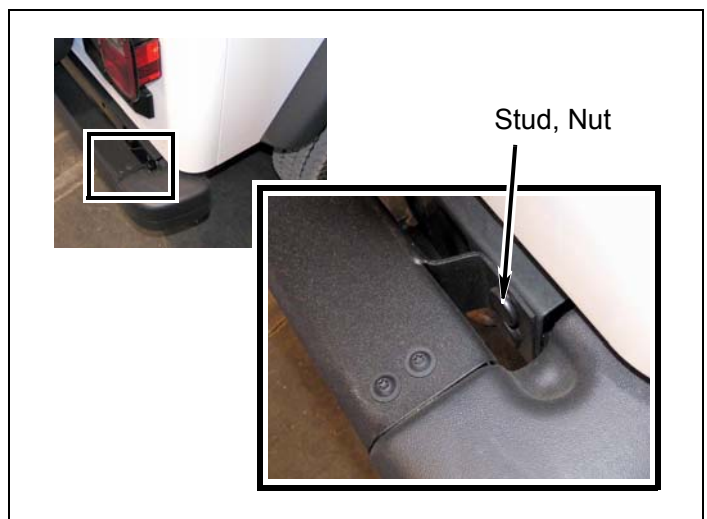

2. Kit bumper

- a. Install kit **bumper** on frame with four kit **bolts** (3/8" x 1"), kit **washers** (3/8" USS), and kit **nuts** (3/8" serrated flange) at outer holes.

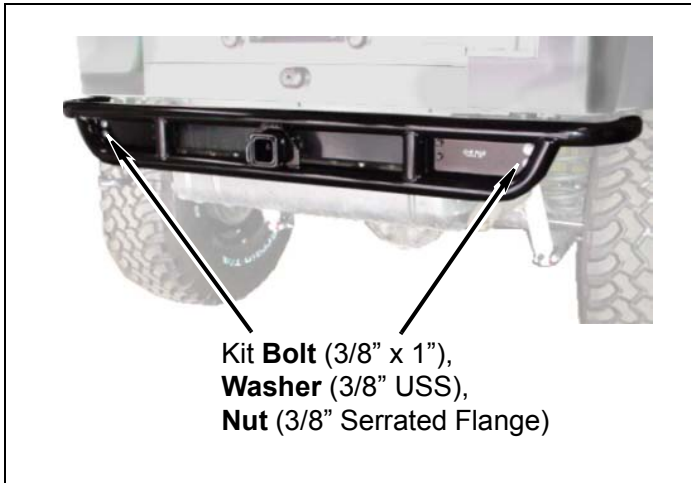

- b. **1987-97 vehicles:** In the remaining holes, secure kit **bumper** to frame cross-plate with four kit **bolts** (3/8" x 1" self-tapping flange-head), kit **washers** (3/8" USS), and kit **nuts** (3/8" serrated flange).

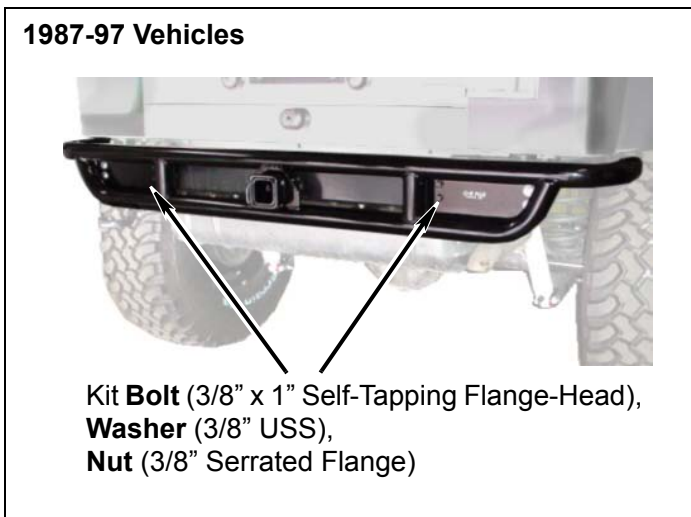

- c. **1998 and later vehicles:** Using any of the remaining holes in kit **bumper** as a template, drill four 5/16" holes in frame cross-plate. Secure kit **bumper** to frame cross-plate with four kit **bolts** (3/8" x 1" self-tapping flange-head) in drilled holes.

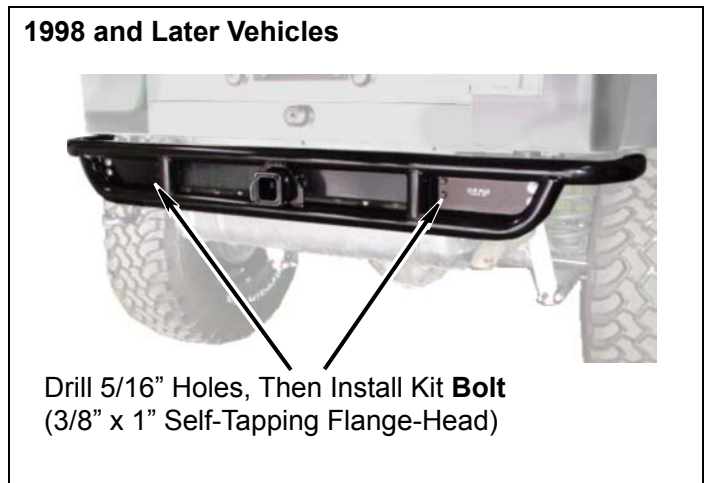

- d. Fasten tow hooks (if equipped) and kit **bumper** to bottom of frame using stock bolts.

Accessories

The following accessories are also available:

Kit # 83095: Rock Slider Front Bumper (YJ)

Kit # 83096: Rock Slider Front Bumper
w/ Grille Guard (YJ)

Kit # 83200: Rock Slider Front Bumper (TJ)

Kit # 83201: Rock Slider Front Bumper
w/ Grille Guard (TJ)

Kit # 84095: Rock Slider Side Bars (YJ)

Kit # 84100: Rock Slider Side Bars (TJ)

Kit # 84200: Rock Slider Rocker Panels (TJ)

Parts list

<u>Qty.</u>	<u>Description</u>
4	Bolt , 3/8" x 1"
4	Bolt , 3/8" x 1" self-tapping flange-head
1	Bumper
8	Nut , 3/8" serrated flange
4	Washer , 3/8" USS